

2006 ELEMENT

Honda

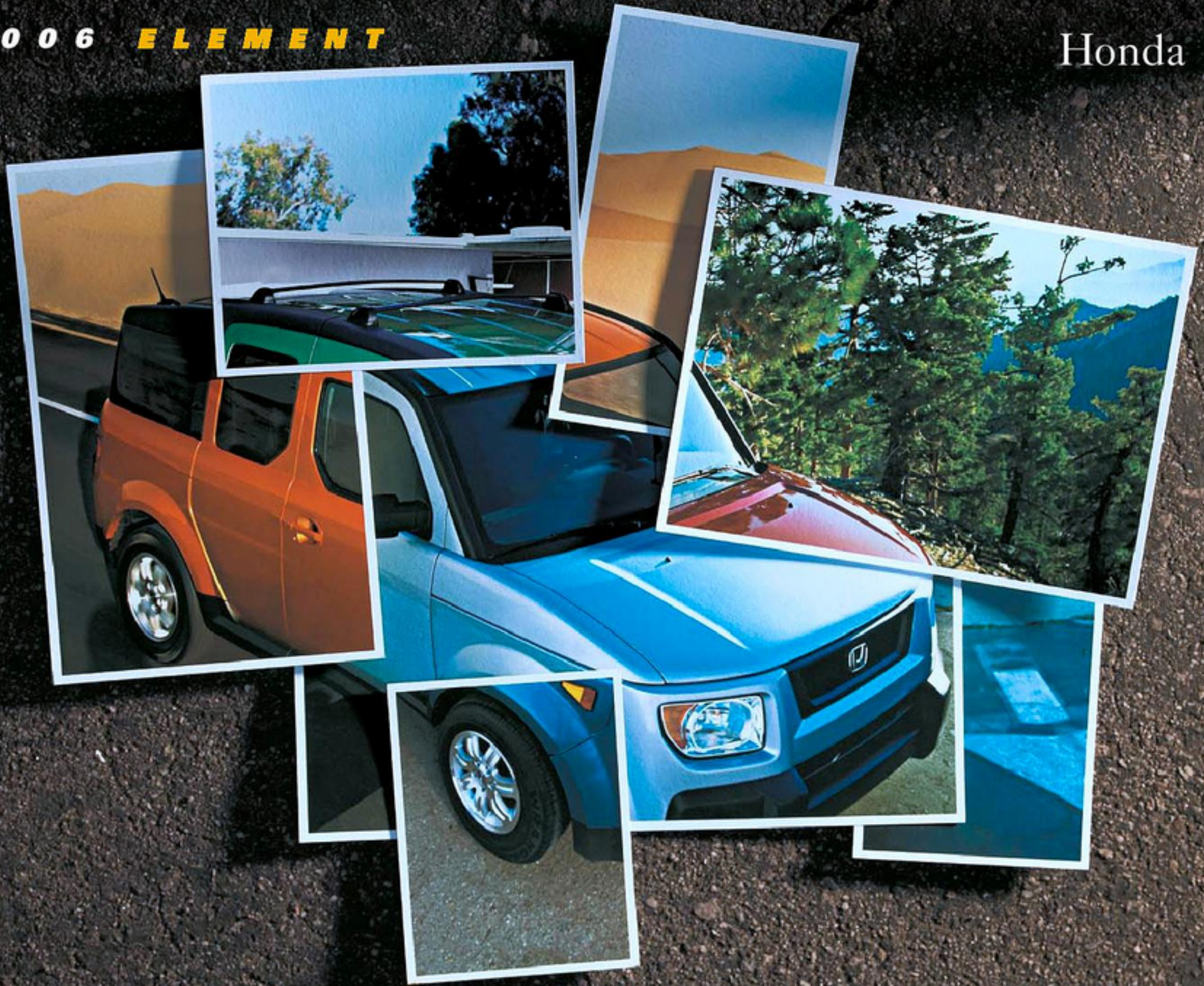



TAKE A TRIP BEYOND ORDINARY



WORK, LIVE, PLAY YOUR OWN WAY

The Element has embodied a unique attitude—call it a freedom from convention. And it turns out, not trying to fit in has made Element just the thing for almost anything you're up to. So load it up and go live life in your own unique way. For '06, there's even the new EX-P model that's painted all one solidly cool color. In case that's your thing.



Element 4WD EX-P shown in Kowl Metallic (available winter 2005) with accessory roof rack.



64

Flip 'em, fold 'em or take the rear seats out for a grand total of 64 configurations. Do the math yourself. Or skip it and just start loving that **BIG-TIME FUNCTIONALITY**. The clam-shell tailgate in the rear and wide-opening side cargo doors make for **EASY LOADING**. Stuff in your mountain bikes, camping supplies, a surfboard—whatever. And don't worry if your gear is muddy, snowy, sandy or just plain funky. The waterproof and stain-resistant FXC™¹ (Fabric for Extreme Conditions) seating surfaces and the low, flat **WIPE-DOWN** urethane-coated utility floor can take the abuse. Get plenty of space, too—up to 77 cubic feet.² There are lots of tie-downs to secure all that cargo, driver-side seatback bungees (EX, EX-P) for odds and ends and a 12-volt power outlet in back. Open up the **REMOVABLE SKYLIGHT** (4WD) and breathe. Looks like you've finally found a vehicle that can keep up with you.

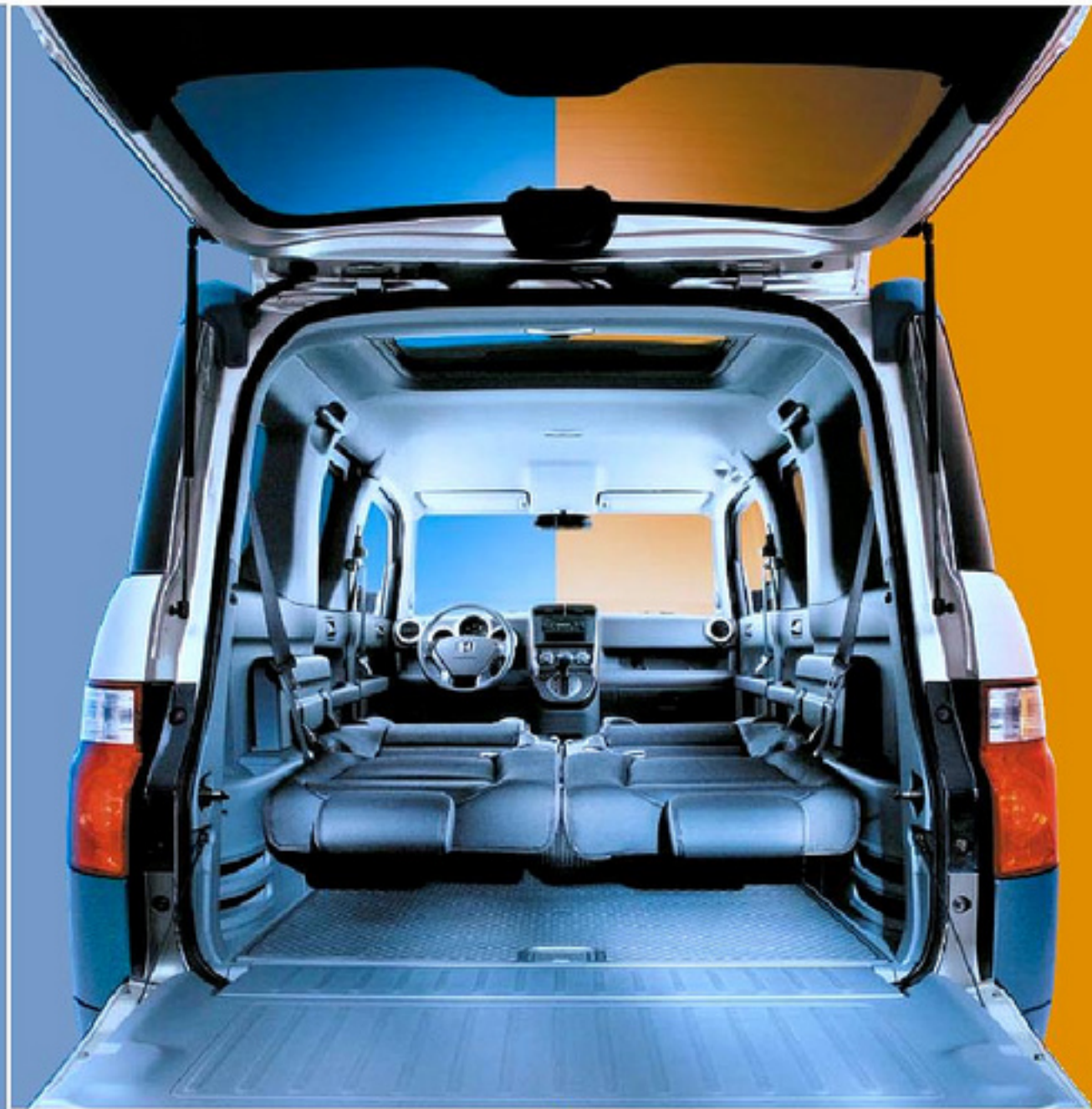

Element 4WD LX shown in Alabaster Silver Metallic with GrayBlue Interior.



Models remind you to properly secure items in the cargo area.





Element 4WD EX-P shown in Tango Red Pearl.

WINDOW DOWN

The Element's power windows get you in touch with the outside world fast. And the smooth driver-side auto-up/down feature frees your fingers to attend to other things.

RADIO UP

The windows are wide open and so is the road ahead. Gas it, and thumb the steering wheel-mounted audio controls to keep those big watts pumping.



PULL UP

When you get there, slide the shifter into park. It's high up, for more space down low. And it's placed so it's easy to grab and slick to shift.

GEAR UP

Got a lot of small stuff? Keep it stashed on the handy non-slip shelf for easy access. Or how about in one of the big door-pocket bins? In the Element, there are options galore.

STAY HYDRATED

There are beverage holders up front and in back, and plenty of console space as well for a snack or two.

CLEAN UP LATER

Go ahead and get dirty. Tidying up the Element is easy after a day of playing hard, thanks to the wipe-down utility floor and waterproof seat fabric.





SLICK SHIFT

Choose the control of the standard 5-speed shifter or the ease of the 4-speed automatic. Either way, the shifter is placed high on the instrument panel so it's easy to get a grip.

TURN IT UP

Standard in EX and EX-P models is one serious stereo. It has a 270-watt amplifier and seven speakers, including a Dynamic Linear Phase subwoofer for monster bass. There's an AM/FM tuner, a CD player that can play MP3 and Windows Media™ Audio⁴ (WMA) discs, and an MP3/auxiliary input jack next to a non-slip shelf.



The EX/EX-P stereo also features XM Satellite Radio.³ It'll deliver over 150 channels of clear, digital-quality sound coast to coast. All music channels are commercial-free. And instant traffic and weather channels keep you informed and on the go.

NO SWEAT

The straightforward climate control makes it easy for you and your passengers to stay comfortable. The knobs are oversized so you can turn them even with gloves on. And every Element model has standard air



INSIDE STUFF

KEEP YOUR EARS HAPPY

Go with an Element LX, and tunes come along for the ride as well. This 4-speaker system features an AM/FM tuner plus a CD player. And if you care what time it is, check the clock.



STOW IT

The Element has plenty of smart places to keep things close at hand. The console storage, an overhead compartment (EX, EX-P) and side storage bins give you lots of space for stuff like CDs, lip balm, keys, sunglasses, water bottles or the map to your next adventure.

Drive responsibly. State laws prohibit distracted driving.



DIALED IN

The Element's big analog gauges have anti-glare lenses, and come in different hues to match the interior you choose. They're easy to read, so you can take a quick glance at the info and keep your eyes focused on more important things, like the road.



Element 4WD EX shown in Atomic Blue Metallic with accessory roof rack, fog lights and aftermarket kayak attachment.

POWER UP



BIG MOTIVATION

The 2.4-liter i-VTEC[®] engine has advanced features like an aluminum-alloy block and head. And it pumps out 156 horses, enough guts to take you just about any place you need to be. When you literally need to haul, you can count on a 1,500-lb. towing capacity.⁵ The Element also qualifies as a Low-Emission Vehicle (LEV-2). But maybe the best thing about what the Element has under its hood is that you hardly ever have to think about it. You can go for 110,000 miles before the first tune-up.*

*Does not apply to fluid and filter changes. See your owner's manual for details.

156

BALANCED POWER

The Element's advanced 16-valve DOHC engine design provides the best of all worlds. Power whenever you need it. Twin balance shafts for smooth, quiet running. And legendary Honda fuel efficiency.⁶

I-VTEC GIVES IT GRUNT

It might sound complex, but it has a simple purpose. The latest version of Honda's variable valve timing and lift electronic control, i-VTEC ("i" is for intelligent) helps produce more torque at lower engine speeds, and more peak horsepower at high revs.

SOPHISTICATED SUSPENSION

The Element has advanced 4-wheel independent suspension that helps smooth out the bumps. Yet handling and steering control still feel direct and precise. In fact, its road manners are probably way better than yours.



MAKE TRACKS



Element 4WD EX shown in Nighthawk Black Pearl with accessory roof rack and snowboard attachment.

SERIOUS SAFETY FEATURES

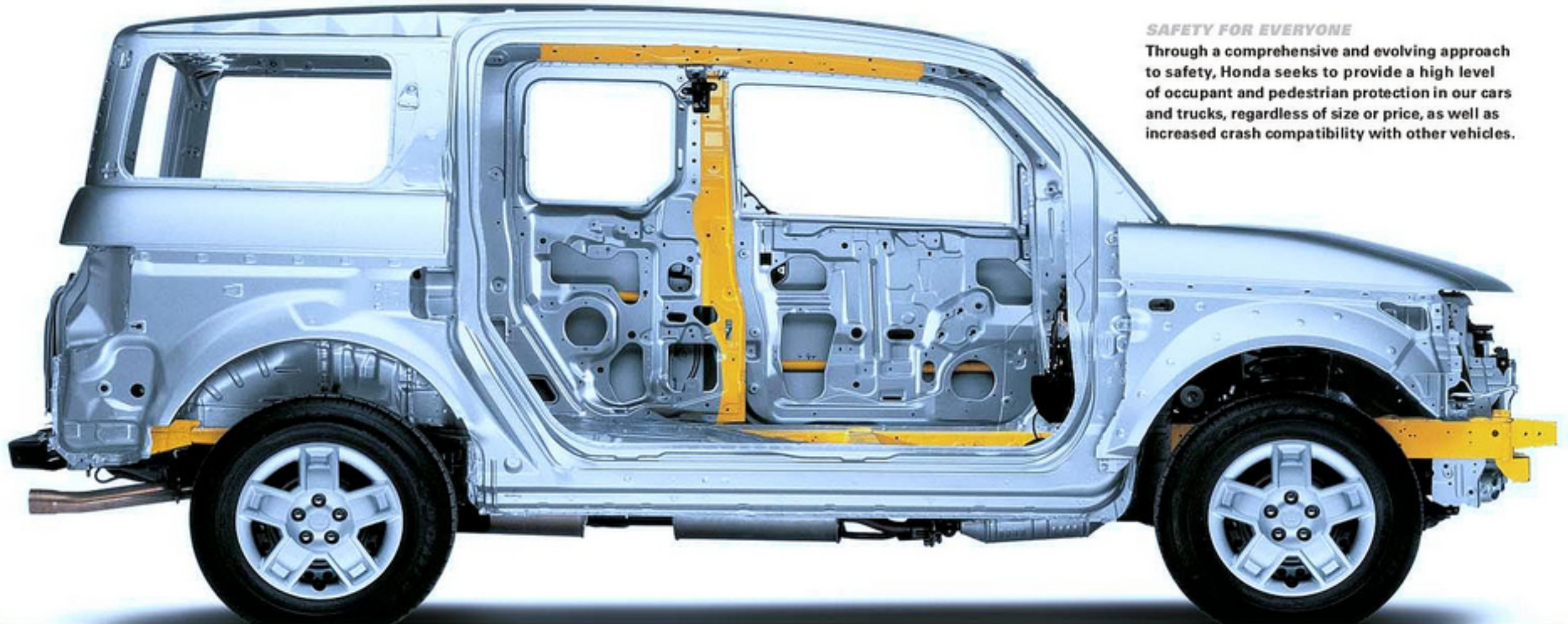

SAFETY FOR EVERYONE

Through a comprehensive and evolving approach to safety, Honda seeks to provide a high level of occupant and pedestrian protection in our cars and trucks, regardless of size or price, as well as increased crash compatibility with other vehicles.

SAFE WHERE YOU LEAVE IT

An Immobilizer Theft-Deterrent System is standard equipment to keep your Element safe—in the “better keep your hands off my truck” sense of the term.

STAR-QUALITY SAFETY RATING

The NHTSA awarded the Element five stars in frontal crash-test ratings*—the best possible for frontal impacts. But then, safety is always a priority in the minds of Honda’s engineers. And while the Element may not have conventional side B-pillars, extremely strong vertical beams are formed when the stoutly reinforced side cargo doors are closed and connect with the Element’s reinforced frame, side sills and roof. It all adds up to a seriously tough passenger compartment.

*National Highway Traffic Safety Administration frontal crash test, March 2003. Government star ratings are part of the National Highway Traffic Safety Administration's (NHTSA) New Car Assessment Program (NCAP), found at safercar.gov.



Element 4WD EX shown in Atomic Blue Metallic with accessory roof rack and aftermarket fork-mount attachment.

IT'S A NO-BRAINER

Two wheels, or four wheels? It doesn't take a whole lot of deliberation when snowy paths or rocky roads are part of your journey. The available Real Time™ 4-wheel drive automatically engages when the going gets rough and you need more traction. When the sophisticated 4WD system senses wheel slippage, it automatically sends power to the rear wheels, helping you right through that tough, tricky terrain. No buttons. No stopping.

STOP IT

The 4-wheel anti-lock brakes (ABS) help prevent wheel lockup to help you maintain steering control during hard braking. All models also feature Electronic Brake Distribution (EBD), which adjusts front-to-rear braking effort to enhance vehicle control and stability.



Front airbags inflate and deflate in a fraction of a second.

DUAL-STAGE, DUAL-THRESHOLD FRONT AIRBAGS

In addition to the three-point seat belts, the front airbags – and on EX and EX-P models, front side airbags – provide added protection in the event of a sufficient impact. And dual-stage, dual-threshold technology enables the front airbags (SRS)* to deploy at one of two rates and thresholds, depending on the force of the impact and seat-belt use.

*Honda reminds you and your passengers to always buckle up. Children 12 and under are safest when properly restrained in the rear seat.

WASH AND WEAR



BOLT ON THE EXTRAS



MAKE IT FIT EVEN BETTER

Whether you're starting with an Element LX, EX or EX-P, your dealer has plenty of ways to help get your Element more like your idea of perfection. For instance, you can add the Element Sport Package, with handy side steps, a fog-light kit and a rear air deflector to add functional good looks.

DEALER-INSTALLED BY THE PACKAGE OR PIECE

Go for the Convenience Package, and get carpeted floor mats, a cargo cover and a cargo net. The Element Lifestyle Package outfits your automatic-equipped vehicle with a roof rack, door visors, a driver-side armrest with storage, and a handy tailgate seatback perfect for lounging.* Or just get all the individual items you like at your Honda dealer - whatever makes your Element perfect.

*Lifestyle Package available with automatic transmission only.



ROOF BOX



INTERIOR BIKE ATTACHMENT



SKYLIGHT SHADE SCREEN



TAILGATE CABANA

SAFETY	LX	EX/EX-P
3-Point Seat Belts at All Seating Positions	*	*
Front 3-Point Seat Belts w/Automatic Tensioning System	*	*
Adjustable Seat Belt Anchors	*	*
Dual-Stage, Dual-Threshold Front Airbags (SRS)	*	*
Front Side Airbags with Passenger-Side Occupant Position Detection System (OPDS)	*	*
Anti-Lock Braking System (ABS)	*	*
Electronic Brake Distribution (EBD)	*	*
Side-Impact Door Beams	*	*
Lower Anchors and Tethers for Children (LATCH)	*	*
Immobilizer Theft-Deterrent System	*	*

EXTERIOR MEASUREMENTS

Wheelbase (in.)	101.4	101.4
Length (in.)	169.3	169.3/170.2
Height (in.)	70.4	70.4
Width (in.)	71.5	71.5
Track (in., front/rear)	62.1/62.3	62.1/62.3
Minimum Ground Clearance (in.)	6.9	6.9
Curb Weight (lbs., 2WD MT/2WD AT)	3371/3429	3391/3441
Curb Weight (lbs., 4WD MT/4WD AT)	3508/3565	3527/3578
Towing Capacity ¹ (lbs.)	1500	1500

INTERIOR MEASUREMENTS

Headroom (in., front/rear; 2WD)	43.3/38.0	43.3/38.0
Headroom (in., front/rear; 4WD)	43.3/39.4	43.3/39.4
Legroom (in., front/rear)	41.0/39.1	41.0/39.1
Shoulder Room (in., front/rear)	57.1/52.2	57.1/52.2
Hiproom (in., front/rear)	55.0/47.6	55.0/47.6
Cargo Volume ² (cu. ft., behind 2nd row; 2WD/4WD)	25.1/26.0	25.1/26.0
Cargo Volume ² (cu. ft., maximum; 2WD/4WD)	74.6/77.1	74.6/77.1
Passenger Volume (cu. ft., 2WD/4WD)	103.6/105.4	103.6/105.4
Seating Capacity	4	4

EXTERIOR FEATURES

Removable Skylight with Tilt Feature	4WD Models Only	4WD Models Only
Slide Cargo Doors	*	*
2-Speed/Intermittent Windshield Wipers	*	*
Rear Window Wiper/Washer	*	*
Remote Entry System	Available	*
Power Side Mirrors	*	*
Rear Privacy Glass	*	*
Clamshell Tailgate	*	*
Multi-Reflector Halogen Headlights	*	*
Chrome Exhaust Finisher	*	*
Body-Colored Door Handles	*	EX-P

COMFORT & CONVENIENCE	LX	EX/EX-P
Air Conditioning with Air-Filtration System	*	*
Power Front Windows w/Auto-Up/Down Driver's Window	*	*
Rear Ventilation Windows	*	*
Power Door and Tailgate Locks	*	*
Cruise Control	*	*
Steering Wheel-Mounted Audio Controls	*	*
Adjustable Steering Column	*	*
Instrument Panel-Mounted Shifter	*	*
Lower Instrument Panel Storage Compartment	*	*
Passenger-Side Vanity Mirror	*	*
Sliding Sun Visor Extensions	*	*
Overhead Storage Compartment	*	*
Map Lights	*	*
Urethane-Coated Utility Floor	*	*
Beverage Holders, Front (3) and Rear (2)	*	*
12-Volt Power Outlets	Front	Front and Rear
Door-Pocket Storage Bins, Rear with Bottle Holders	*	*
Passenger-Side Seatback Pocket	*	*
Driver-Side Seatback Bungees, Front and Rear	*	*
Rear Window Defroster	*	*
Rear-Seat Heater Ducts	*	*
Cargo Area Tie-Down Anchors (4)	*	*
Cargo Area Storage Bins	*	*
Cargo Area Hooks (2)	*	*
Cargo Area Light	*	*

SEATING

Driver's Seat with Manual Height Adjustment	*	*
Waterproof FXC™ (Fabric for Extreme Conditions) Seat Fabric	Front	Front and Rear
Adjustable Head Restraints, Front and Rear	*	*
Driver- and Passenger-Side Armrests	*	*
Removable, Flip-Up Rear Seats	*	*
Fold-Flat-Capable Seating	*	*

AUDIO SYSTEMS

AM/FM/CD Audio System with 4 Speakers and Clock	*	*
270-Watt AM/FM/CD Audio System with 7 Speakers, Including Subwoofer	*	*
MP3/Windows Media™ Audio ⁴ (WMA) Playback Capability	*	*
XM [®] Satellite Radio ³	*	*
MP3/Auxiliary Input Jack	*	*

SPECIFICATIONS AND FEATURES



WE'RE HERE.

Your dealer's team of trained technicians is at the ready to help keep your Honda in superb shape. All 2006 Honda vehicles – and any Genuine Honda Accessories installed at the time of purchase – are covered by the 3-year/36,000-mile New-Vehicle Limited Warranty.⁷ Plus, Honda cars and trucks are covered by a 5-year/60,000-mile Limited Powertrain Warranty, too. For more information or assistance, see your Honda dealer or please give us a call at 1-800-33-Honda.

HONDA Financial Services

Whether you buy or lease, Honda Financial Services can help you with the process. And the College Graduate Program offers recent graduates flexible and competitive financing, leasing and purchasing packages on any new or Certified Used Honda. Ask your dealer for details.

Honda CareSM is a comprehensive and affordable vehicle and travel protection plan that is backed by Honda reliability, service and parts. See your Honda dealer for more information.



¹FXCSM is a trademark of Milliken & Company. ²Carrying too much cargo or improperly storing it can affect the handling, stability and operation of the vehicle. Before carrying any cargo, be sure to consult the owner's manual for load limits and loading guidelines. ³Required XMSM subscription sold separately after three trial months. All fees and programming subject to change. Subscriptions subject to Customer Agreement available at xmradio.com. XM service only available in the 48 contiguous United States. The XM name is a registered trademark of XM Satellite Radio Inc. ⁴Windows MediaSM Audio is a trademark of MicrosoftSM Corporation. ⁵Towing requires the addition of the Honda accessory trailer hitch and hitch ball. Refer to the owner's manual for additional towing information. ⁶Based on 2006 EPA mileage estimates. Use for comparison purposes only. Actual mileage may vary. ⁷3-Year/36,000-Mile Limited Warranty. 5-Year/60,000-Mile Limited Powertrain Warranty. Ordinary maintenance or adjustments, parts subject to normal wear and replacement, and certain items are excluded. See your Honda dealer for terms and conditions of the limited warranties. Always use seat belts and appropriate child seats. Children 12 and under are safest when properly restrained in the rear seat. Specifications, features, illustrations and equipment shown in this brochure are based upon the latest available information at the time of printing. Although descriptions are believed to be correct, accuracy cannot be guaranteed. American Honda Motor Co., Inc., reserves the right to make changes at any time, without notice or obligation, in colors, specifications, accessories, materials and models. Some vehicles may be shown with optional equipment. Available – Optional. All images contained herein are either owned by American Honda Motor Co., Inc., or used under a valid license. It is a violation of federal law to reproduce these images without express written permission from American Honda Motor Co., Inc., or the individual copyright owner of such images. Honda Financial Services is a DBA of American Honda Financial Corp. Honda, the H-mark symbol, Honda Care, i-VTEC and Real Time are trademarks of Honda Motor Co., Ltd. ©2005 American Honda Motor Co., Inc.

ENGINEERING

	LX	RX/RX-P
Engine Type	In-Line 4-Cylinder	In-Line 4-Cylinder
Engine Block/Cylinder Head	Aluminum-Alloy	Aluminum-Alloy
Displacement (cc)	2354	2354
Horsepower @ rpm (SAE net, Rev 8/04)*	158 @ 5500	158 @ 5500
Torque (lb.-ft. @ rpm)*	180 @ 4500	180 @ 4500
Compression Ratio	9.7:1	9.7:1
Valve Train	16-Valve DOHC i-VTEC*	16-Valve DOHC i-VTEC
Multi-Point Fuel Injection	•	•
Drivetrain	2WD or Real Time SM 4-Wheel Drive	2WD or Real Time 4-Wheel Drive
CARB Emissions Rating	LEV-2	LEV-2
Direct Ignition System with Immobilizer	•	•
110,000-Mile Tune-Up Interval†	•	•

TRANSMISSIONS

5-Speed Manual Transmission	•	•
Gear Ratios: 1st: 3.533, 2nd: 2.042, 3rd: 1.355, 4th: 1.028, 5th: 0.825, Reverse: 3.583, Final Drive: 4.765		
4-Speed Automatic Transmission (Available)	•	•
Gear Ratios: 1st: 2.684, 2nd: 1.535, 3rd: 1.081, 4th: 0.733, Reverse: 2.000, Final Drive: 4.438		

BODY/SUSPENSION/CHASSIS

Unit-Body Construction	•	•
Control-Link MacPherson Strut Front Suspension	•	•
Compact Double Wishbone Rear Suspension	•	•
Stabilizer Bar (mm, front/rear)	30.0/21.0	30.0/21.0
Variable Power-Assisted Rack-and-Pinion Steering	•	•
Turning Diameter, Curb-to-Curb (ft.)	34.9	34.9
Power-Assisted 4-Wheel Disc Brakes	•	•
Wheels	16" with Full Covers	16" Alloy
All-Season Tires	P215/70 R16	P215/70 R16

EPA MILEAGE ESTIMATES¹/FUEL CAPACITY

5-Speed Manual (City/Highway, 2WD)	21/25	21/25
4-Speed Automatic (City/Highway, 2WD)	22/26	22/26
5-Speed Manual (City/Highway, 4WD)	21/24	21/24
4-Speed Automatic (City/Highway, 4WD)	21/24	21/24
Fuel (gal.)	15.9	15.9
Required Fuel	Regular Unleaded	Regular Unleaded

INSTRUMENTATION

Digital Odometer and Digital Trip Meters (2)	•	•
Tailgate-Open Indicator	•	•
Fuel and Coolant Temperature Indicators	•	•
Low-Fuel Indicator	•	•